

CD Power Amplifier Owner's Manual

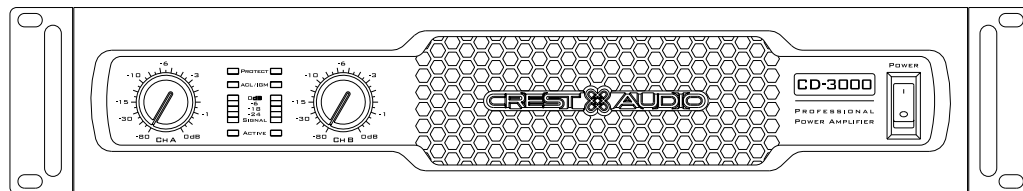



Intended to alert the user to the presence of uninsulated “dangerous voltage” within the product’s enclosure that may be of sufficient magnitude to constitute a risk of electric shock to persons.



Intended to alert the user of the presence of important operating and maintenance (servicing) instructions in the literature accompanying the product.

CAUTION: Risk of electrical shock — DO NOT OPEN!

CAUTION: To reduce the risk of electric shock, do not remove cover. No user serviceable parts inside. Refer servicing to qualified service personnel.

WARNING: To prevent electrical shock or fire hazard, do not expose this appliance to rain or moisture. Before using this appliance, read the operating guide for further warnings.



Este símbolo tiene el propósito, de alertar al usuario de la presencia de “(voltaje) peligroso” sin aislamiento dentro de la caja del producto y que puede tener una magnitud suficiente como para constituir riesgo de descarga eléctrica.



Este símbolo tiene el propósito de alertar al usuario de la presencia de instrucciones importantes sobre la operación y mantenimiento en la información que viene con el producto.

PRECAUCION: Riesgo de descarga eléctrica ¡NO ABRIR!

PRECAUCION: Para disminuir el riesgo de descarga eléctrica, no abra la cubierta. No hay piezas útiles dentro. Deje todo mantenimiento en manos del personal técnico cualificado.

ADVERTENCIA: Para evitar descargas eléctricas o peligro de incendio, no deje expuesto a la lluvia o humedad este aparato. Antes de usar este aparato, lea más advertencias en la guía de operación.



Ce symbole est utilisé dans ce manuel pour indiquer à l'utilisateur la présence d'une tension dangereuse pouvant être d'amplitude suffisante pour constituer un risque de choc électrique.



Ce symbole est utilisé dans ce manuel pour indiquer à l'utilisateur qu'il ou qu'elle trouvera d'importantes instructions concernant l'utilisation et l'entretien de l'appareil dans le paragraphe signalé.

ATTENTION: Risques de choc électrique — NE PAS OUVRIR!

ATTENTION: Afin de réduire le risque de choc électrique, ne pas enlever le couvercle. Il ne se trouve à l'intérieur aucune pièce pouvant être réparée par l'utilisateur. Confiez l'entretien et la réparation de l'appareil à un réparateur agréé.

AVERTISSEMENT: Afin de prévenir les risques de décharge électrique ou de feu, n'exposez pas cet appareil à la pluie ou à l'humidité. Avant d'utiliser cet appareil, lisez attentivement les avertissements supplémentaires de ce manuel.



Dieses Symbol soll den Anwender vor unisolierten gefährlichen Spannungen innerhalb des Gehäuses warnen, die von Ausreichender Stärke sind, um einen elektrischen Schlag verursachen zu können.



Dieses Symbol soll den Benutzer auf wichtige Instruktionen in der Bedienungsanleitung aufmerksam machen, die Handhabung und Wartung des Produkts betreffen.

VORSICHT: Risiko — Elektrischer Schlag! Nicht öffnen!

VORSICHT: Um das Risiko eines elektrischen Schlages zu vermeiden, nicht die Abdeckung entfernen. Es befinden sich keine Teile darin, die vom Anwender repariert werden könnten. Reparaturen nur von qualifiziertem Fachpersonal durchführen lassen.

ACHTUNG: Um einen elektrischen Schlag oder Feuergefahr zu vermeiden, sollte dieses Gerät nicht dem Regen oder Feuchtigkeit ausgesetzt werden. Vor Inbetriebnahme unbedingt die Bedienungsanleitung lesen.

IMPORTANT SAFETY INSTRUCTIONS

WARNING: When using electrical products, basic cautions should always be followed, including the following:

1. Read these instructions.
 2. Keep these instructions.
 3. Heed all warnings.
 4. Follow all instructions.
 5. Do not use this apparatus near water.
 6. Clean only with a dry cloth.
 7. Do not block any of the ventilation openings. Install in accordance with manufacturer's instructions.
 8. Do not install near any heat sources such as radiators, heat registers, stoves or other apparatus (including amplifiers) that produce heat.
 9. Do not defeat the safety purpose of the polarized or grounding-type plug. A polarized plug has two blades with one wider than the other. A grounding type plug has two blades and a third grounding prong. The wide blade or third prong is provided for your safety. If the provided plug does not fit into your outlet, consult an electrician for replacement of the obsolete outlet.
 10. Protect the power cord from being walked on or pinched, particularly at plugs, convenience receptacles, and the point they exit from the apparatus.
 11. Only use attachments/accessories provided by the manufacturer.
 12. Use only with a cart, stand, tripod, bracket, or table specified by the manufacturer or sold with the apparatus. When a cart is used, use caution when moving the cart/apparatus combination to avoid injury from tip-over.
- 
13. Unplug this apparatus during lightning storms or when unused for long periods of time.
 14. Refer all servicing to qualified service personnel. Servicing is required when the apparatus has been damaged in any way, such as power-supply cord or plug is damaged, liquid has been spilled or objects have fallen into the apparatus, the apparatus has been exposed to rain or moisture, does not operate normally, or has been dropped.
 15. Never break off the ground pin. Write for our free booklet "Shock Hazard and Grounding." Connect only to a power supply of the type marked on the unit adjacent to the power supply cord.
 16. If this product is to be mounted in an equipment rack, rear support should be provided.
 17. Exposure to extremely high noise levels may cause a permanent hearing loss. Individuals vary considerably in susceptibility to noise-induced hearing loss, but nearly everyone will lose some hearing if exposed to sufficiently intense noise for a sufficient time. The U.S. Government's Occupational and Health Administration (OSHA) has specified the following permissible noise level exposures:

Duration Per Day In Hours	Sound Level dBA, Slow Response
8	90
6	92
4	95
3	97
2	100
1 1/2	102
1	105
1/2	110
1/4 or less	115

According to OSHA, any exposure in excess of the above permissible limits could result in some hearing loss. Ear plugs or protectors to the ear canals or over the ears must be worn when operating this amplification system in order to prevent a permanent hearing loss, if exposure is in excess of the limits as set forth above. To ensure against potentially dangerous exposure to high sound pressure levels, it is recommended that all persons exposed to equipment capable of producing high sound pressure levels such as this amplification system be protected by hearing protectors while this unit is in operation.

SAVE THESE INSTRUCTIONS !

important precautions

- ① **Save the carton and packing materials!** Should you ever need to ship the unit, use only the original factory packing.

For replacement packaging, call Crest Audio's Customer Service Department directly.

- ② **Read all documentation before operating your equipment.** Retain all documentation for future reference.
- ③ **Follow all instructions printed on unit chassis for proper operation.**
-

- ④ **Never hold a power switch or circuit breaker in the on-position, if it won't stay there by itself!**

- ⑤ **Do not use the unit if the electrical power cord is frayed or broken.** The power supply cords should be routed so that they are not likely to be walked on or pinched by items placed upon or against them.

- ⑥ **Always operate the unit with the AC ground wire connected to the electrical system ground.** Precautions should be taken so that the means of grounding of a piece of equipment is not defeated.

- ⑦ **Damage caused by connection to improper AC voltage is not covered by any warranty.** Mains voltage must be correct and the same as that printed on the rear of the unit.

- ⑧ **Do not ground any hot (red) terminal. Never connect a hot (red) output to ground or to another hot (red) output!**
-

- ⑨ **Power down and disconnect units from mains voltage before making connections.**

- ⑩ **Do not drive the inputs with a signal level greater than that required to enable equipment to reach full output.**

- ⑪ **Do not run the output of any amplifier channel back into another channel's input.**

Do not parallel- or series-connect an amplifier output with any other amplifier output.

Crest Audio is not responsible for damage to loudspeakers for any reason.

- ⑫ **Do not connect the inputs or outputs of amplifiers to any other voltage source:** such as a battery, mains source, or power supply, regardless of whether the amplifier is turned on or off.

- ⑬ **Connecting amplifier outputs to oscilloscopes or other test equipment while the amplifier is in bridged mono mode may damage both the amplifier and test equipment!**
-

- ⑭ **Do not spill water or other liquids into or on the unit, or operate the unit while standing in liquid.**

- ⑮ **Do not block fan intake or exhaust ports.**

Do not operate equipment on a surface or in an environment which may impede the normal flow of air around the unit: such as a bed, rug, weathersheet, carpet, or completely enclosed rack.

- ⑯ **If the unit is used in an extremely dusty or smoky environment:** the unit should be periodically blown free of foreign matter.

- ⑰ **Do not use the unit near stoves, heat registers, radiators, or other heat producing devices.**

- ⑱ **The power cord of equipment should be unplugged from the outlet when left unused for a long period of time.**

Service Information

Do not remove the cover!

Removing the cover will expose you to potentially dangerous voltages. There are no user serviceable parts inside.

Equipment should be serviced by qualified service personnel when:

- A. The power supply cord or the plug has been damaged.
- B. The equipment has been exposed to rain.
- C. The equipment does not appear to operate normally, or exhibits a marked change in performance.
- D. The equipment has been dropped, or the enclosure damaged.

To obtain service:

contact your nearest Crest Audio Service Center, Distributor, Dealer, or Crest Audio at 201.909.8700 USA or visit www.crestaudio.com for additional information.

email techserve@crestaudio.com



This symbol is used to alert the operator to follow important procedures and precautions detailed in documentation.



This symbol is used to warn operators that uninsulated "dangerous voltages" are present within the equipment enclosure that may pose a risk of electric shock.

This equipment conforms to EN55022 Class A. In a domestic environment this product may cause radio interference in which case the user may be required to take adequate measures.

This equipment has been tested and found to comply with the limits for a Class B digital device pursuant to part 15 of the FCC Rules. These limits are designed to provide reasonable protection against harmful interference in a residential installation. This equipment generates, uses and can radiate radio frequency energy and, if not installed and used in accordance with the instructions, may cause harmful interference to radio communications. However, there is no guarantee that interference will not occur in a particular installation. If this equipment does cause harmful interference to radio or television reception, which can be determined by turning the equipment off and on, the user is encouraged to try to correct the interference by one or more of the following measures:

*Reorient or relocate the receiving antenna.

*Increase the separation between the equipment and the receiver.

*Connect the equipment into an outlet on a circuit different from that to which the receiver is connected.

*Consult the dealer or an experienced radio/TV technician for help.

table of contents

- 1 how to use this manual p.2
 - introduction p.3
- 2 installation p.5
 - unpacking
 - mounting
 - cooling and ventilation
 - powering
 - maintenance
- 3 features overview p.9
 - front panel
 - rear panel
- 4 operation modes p.15
 - stereo
 - parallel
 - bridged
- 5 connections p.17
 - input
 - output
- 6 safety p.21
 - tourclass protection
 - precautions
 - user responsibility
- 7 service and support p.25
 - support
 - contact us
 - registration

- a specifications p.27
- b block diagram p.28
- c optional handle installation p.29
- d wire gauge charts p.30

contents

appendices

conventions

terms

official Crest Audio features and each indicator or control on the amplifier will appear as: *terms*

actions

specific actions or selections the user can execute will appear as: *actions*

tasks

are broken down into steps 

warnings

Procedures **not** to attempt. 
Issues or hazards to keep in mind when operating the equipment.

indicators

What to look for on the equipment display. 
Alerts, indicators, or prompts that may appear.

tips

Preferred methods. 
Helpful hints.
Feature insights.

see

see—refers to other sections of the manual containing supplementary information on the current topic or a related issue

note

note—supplementary feature information

welcome

Congratulations on your purchase of a new CD Series professional power amplifier and thank you for your confidence in Crest Audio products. You are among the growing number of audio professionals who have made Crest Audio one of the world's leading suppliers of professional and commercial/industrial audio systems.

For your safety, please read the Important Precautions section before installing and operating the amplifier. The Crest Audio CD Series amplifiers are designed for high operating efficiency and accurate sonic performance across the full audio bandwidth, even under stressful conditions.

The Crest Audio CD series amplifiers utilize Class D amplifier technology which greatly improves the efficiency of the amplifier and reduces the power demand from the mains supply. The CD amplifier incorporates a linear power supply design and are built to uncompromising standards. This, combined with major advances in amplifier technology provides for extreme reliability and sonic accuracy for which Crest products are renown.

linear-toroid power supply

A traditional linear power supply is used in the CD Series. Because of the amplifier section's efficiency, (approx 80%) the transformer does not need to be as big or as heavy. This gives the CD Series an advantage in delivering more power in a more compact package.

The efficiency of the output stage also gives the power supply the ability to handle heavy-duty cycles without compromising sonic integrity.

In order to maintain strict quality assurance standards, all Crest Audio power amplifiers are built in our state-of-the-art USA manufacturing facility. Internal components are the finest available and key sub-assemblies are pre-tested before final assembly. Each amplifier is "burned in" and thoroughly tested (using precision audio test equipment) before shipping. In addition, all CD Series amplifiers incorporate Crest's exclusive TourClass® protection features to safeguard both internal circuitry and connected loudspeakers.

This proven combination of advanced design, quality construction and comprehensive circuit protection is your guarantee of fail-safe reliability. You can depend on consistent, stable performance even when your CD Series amplifier is subjected to punishing extremes in the most demanding fixed or mobile sound reinforcement applications.

- what to do with the shipping carton
- proper rack-mounting technique
- keeping the amplifier cooled
- required AC line voltages
- routine maintenance practices

unpacking

mounting

cooling and
ventilation

powering

maintenance

2 installation

unpacking

Please inspect the amplifier carefully immediately after unpacking. If you find any damage, notify your supplier/dealer immediately. Only the shipper may file a damage claim with the carrier for damage incurred during shipping. Be sure to save the carton and all packing materials for the carrier's inspection.

If the packing materials are in good condition, please save them. If you ever need to ship the unit anywhere without mounting it in a rack, you should take advantage of the original factory packing materials in order to avoid unnecessary damage.

For replacement packaging, call Crest Audio's Customer Service Department directly. see—service and support



mounting

All CD Series amplifiers mount in standard 19-inch racks and occupy two rack spaces. Four front-panel mounting holes are provided on each amplifier. Rear mounting ears give additional support and use of rear supports is highly recommended in all mobile and touring sound systems. Handles are available as an option (P/N: C32000010).

CD dimensions

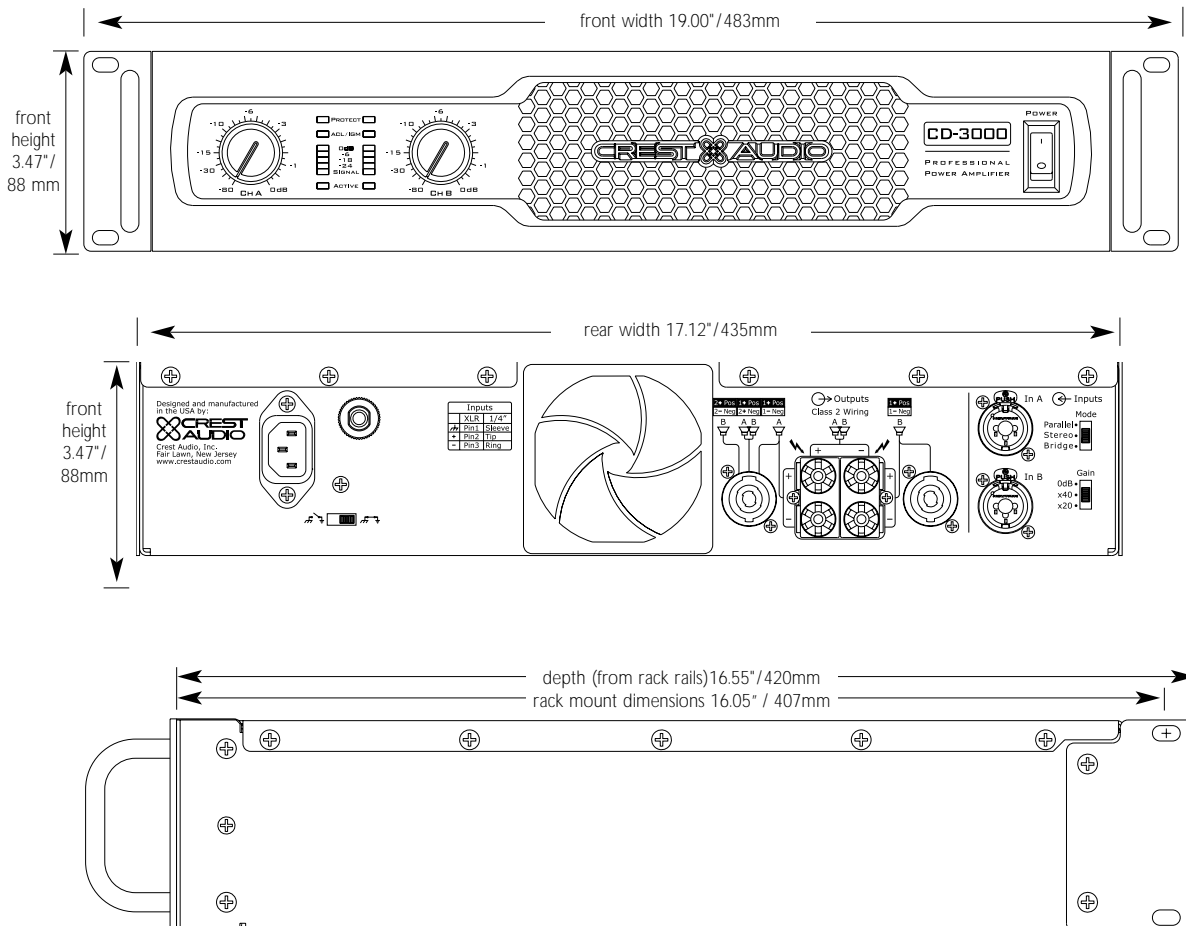

cooling and ventilation

CD amplifiers use a forced air cooling system to maintain a low, even operating temperature.

Air is drawn in by a DC fan on the rear panel, flows through the cooling fins and then exhausts through the front panel vent.

Heat sink temperature is monitored and controls the variable speed fan. Fan speed increases only as required, keeping fan noise to a minimum.

Keep this unit 8" from any combustible surface on all sides.

If the heat sink surpasses its maximum allowed temperature, the thermal protection circuit will activate and open the output relays allowing the amplifier to cool to a safe temperature. Normal operation will resume once the amplifier cools to a safe level.

Thermal protect activation only occurs under extreme thermal conditions and is not part of normal operation.

Make certain that there is enough space around the front and rear of the amplifier to allow the heated air to escape. When mounting in a rack, try to avoid using doors or covers on the front and rear of the enclosure; the exhaust air must not be impeded



suggestion

In racks with closed backs allow at least **one** standard-rack-space opening for every four amps.

powering

Unless otherwise specified when ordered, CD amplifiers are supplied factory set to following voltage options :

Option 1 US domestic nominal 120Vac 60Hz for rated power output
(safe operating range 100 - 132Vac)

Option 2 export models nominal 230Vac 50Hz for rated power output
(safe operating range 200 - 253Vac)

maintenance

On some CD amplifier models the fan is supplied with a removable foam filter. This filter should be cleaned periodically with compressed air.

If the amplifier is used in an extremely dusty or smoky environment , the unit should be periodically blown free (using compressed air) of any foreign matter that may have built up inside the unit.

Users will not need to make any adjustments to the amplifier during its lifetime. There are no user-serviceable parts or adjustments that require opening the amplifier.

features overview 3

- location of connectors and controls
- legend of panel symbols

front panel

rear panel

3 features overview

CD shown

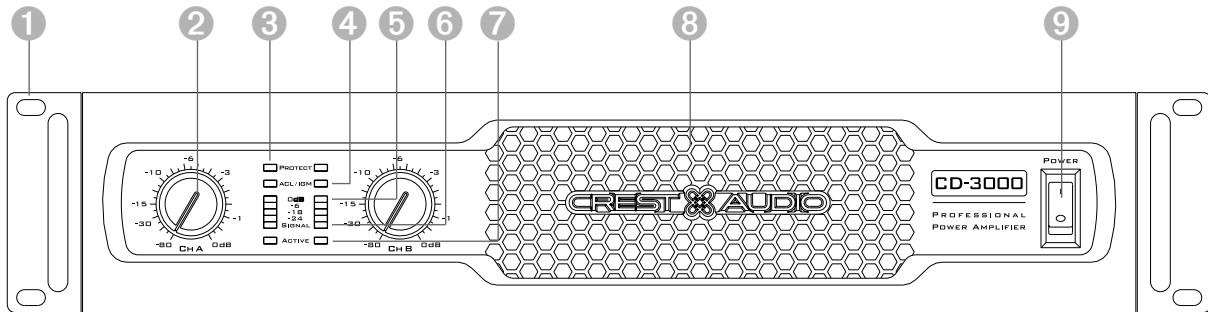

front panel

1 Rack Mounting Ears

Two front-panel mounting holes are provided on each mounting ear.

2 Channel Level attenuators

Two input attenuators adjust level for their respective amplifier channels in stereo and in parallel modes. In Bridged Mono mode, the channel A attenuator controls overall signal level for both channels (see rear panel mode switch description).

3 Protect

This Red LED indicates that the amp channel is in Protect mode. During Power up, the amp briefly goes into protect mode in order to prevent any loud spikes from being fed to the speakers. After a few seconds the amp comes out of protect mode and is ready for normal operation. If the amp stays in Protect mode, this indicates that there may be a problem internal to the amp. If the amp goes into Protect mode during operation this indicates that either a problem has developed internal to the amplifier or the amplifier is being over-stressed due to an over-current (short circuit or a load impedance below the operating range), or thermal condition. In this event, the amplifier should be switched OFF, and the load connections checked for shorts and proper load impedance. If overheating is suspected, allow the amplifier to cool and check that the airflow is not impeded.

4 ACL / IGM

This Red LED illuminates when either the ACL or IGM protection circuitry is engaged. See Section 6, Tourclass Protection for more information on these Crest-exclusive features.

5 -24, -18, -6, 0dB

The first three LEDs (-24, -18, -6) are Green and the last led, 0dB is yellow. These LEDs respond to the incoming program material as peak meters. Under normal operating conditions the Green LEDs illuminate with the dynamics of the program material and the Yellow LED flashes during the loudest peaks.

6 Signal

Green LED varies in intensity in response to signals below -24 dB.

7 Active

Green LED illuminates when the amp is on to show that the channel is active.

8 Fan Outlet Grill

CD Series amplifiers are cooled by a single rear-mounted fan. Cool air flows over the heat sink and exhausts through the front grill. Make sure this outlet remains clear to allow unrestricted airflow.

9 Power switch

This switch turns the amp on and off. If the amp doesn't turn on when the switch is in the **ON** position, check the circuit breaker on the rear panel.

The power only breaks one side of the AC mains. Hazardous energy may be present in the enclosure when the power switch is in the off position.



3 features overview

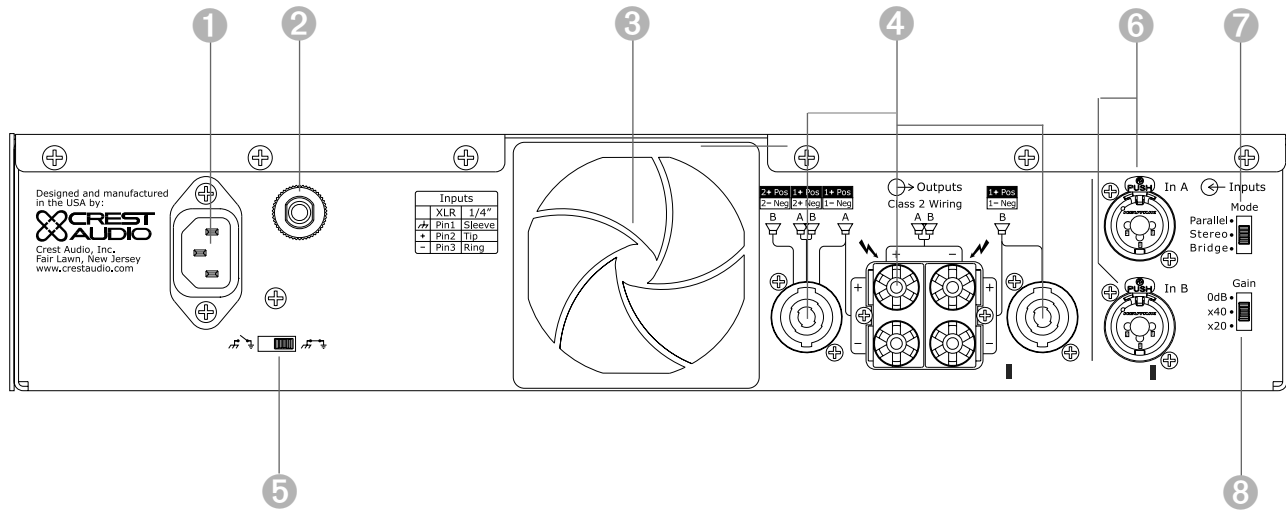

rear panel

1 IEC power connector

Accepts a standard IEC terminated power cable















2 Breaker

Resettable circuit breaker - no fuses are used. Breaker can trip due to a power surge or over-voltage condition. If it trips once, reset it. If it continues to trip, the amplifier may need servicing.

3 Fan

The fan operates continuously while the amp is on. An internal temperature sensor increases the speed of the fan during high temperature conditions. Air enters through the rear of the amp and exits through the front grill. Be sure to allow adequate air flow from the rear of the rack the amp is mounted in.

rear panel legend

-  input connection
-  XLR connector polarity
-  TRS connector polarity
-  bridged mono mode
-  parallel mode
-  stereo mode
-  chassis ground lifted-position
-  chassis ground grounded-position
-  output connection
-  speakon output channel A stereo/parallel
-  channel B stereo/parallel
-  bridged mono
-  five-way binding post channel A stereo/parallel
-  bridged mono
-  channel B stereo/parallel

rear panel

4 Output connections

Speakers can be connected via the high current binding posts and the industry-standard Speakon (NL-4) connectors.

Binding posts: One pair (Red- hot, Black- ground) per channel.

Speakons - One connector for each channel. The Speakon connector for Channel A also contains contacts for Channel B output as well (see Operation Modes).

5 Ground lift switch

The recessed two-position ground lift switch is used to isolate the amp's signal ground from the chassis/AC ground. The factory default setting is to the right, Grounded. To lift, or disconnect the signal ground from the chassis/AC ground, slide the switch to the left. Never lift the ground prong on the AC connector.

6 Input connections

Input signals can be connected to the amp via the Combi connectors, the 1/4" TRS connectors, and the Female XLR (pin 2 hot) connectors. See Connections

7 Mode selector switch

This recessed, three position switch configures the amplifier for Stereo, Parallel or Bridged Mono operation. The default factory setting is Stereo. See - operation modes.

8 Input sensitivity switch

This three position switch allows the user to select the input sensitivity to .775v (0 dBu), X20, or X40 for full rated output power. The default factory setting is X20.

Never connect a speaker of LESS than 2Ω minimum impedance to an individual channels' output connections when operating in STEREO or PARALLEL mode. 

Never connect a speaker of LESS than 4Ω minimum impedance to Channel A and B "+" output connections when operating in BRIDGE mode. In BRIDGE mode operation, the amplifier can produce output voltages exceeding 120VRMS. Use extreme caution. 

Never connect a **hot** (red) output to ground or to another **hot** (red) output! 

In situations where an UNBALANCED signal is fed to the amp, it's important to ground the unused input. If the inverting (-) input of an amp channel is left floating, the channels gain will drop by 6 dB. In effect, the amp will not be as loud. For more information about this, ask your dealer or contact Crest Audio Technical Support directly. 

Do **not** adjust the mode selection switch while the amplifier is turned-on. 

operation modes 4

- ▶ choosing the appropriate mode
- ▶ switching between operation modes
- ▶ special considerations when using bridged mode

stereo

parallel

bridged

4 operation modes

mode selection

The three-position, recessed Mode Select switch (located on the rear panel) configures the amplifier for Stereo, Parallel or Bridged mode. Amplifiers are factory-configured for Stereo mode. Shut the amp off before changing modes.

stereo

In Stereo mode, both channels operate independently, with their input attenuators controlling their respective levels. Signal at Channel A's input produces output at Channel A's output, while signal at Channel B's input produces output at Channel B's output. Recommended minimum nominal load impedance for stereo operation is 2 Ohms per channel.

parallel

When set to Parallel mode, program material applied to Channel A's input will appear at both Channel A and B outputs. The attenuators for Channel A and B controls the level for channel A and B outputs independently of each other.

bridged

Bridged mode straps both amplifier channels together to make a single-channel monaural amplifier. One channel *pushes* and the other *pulls* equally, increasing the power output over that of either channel alone (see Specifications). Signal is applied to the Channel A input only. Channel A's attenuator is used to control signal level.

Use extreme caution when operating the amplifier in Bridged mode. Never ground either side of the speaker cable when the amplifier is in Bridged mode; both sides are "hot."

If an output patch panel is used, all connections must be isolated from each other and from the panel. The recommended minimum nominal load impedance in the Bridged mode is 4 ohms, which is the equivalent to driving both channels separately at 2 ohms.

see—connections for examples of mode-specific wirings

Connecting amplifier outputs to oscilloscopes or other test equipment while the amplifier is in **bridged** mode may damage both the amplifier and test equipment!



- proper wiring schemes for connectors: speakon
binding post

- correct signal paths: stereo, parallel and bridged

input
XLR 1/4" TRS
Combi

output
Binding Posts
Speakons

inputs

CD amplifiers are configured standard with pin 2 hot on XLR inputs.

female XLR

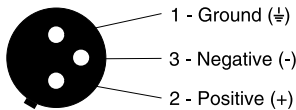

TRS pinouts

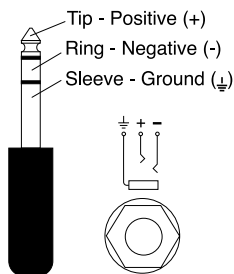

outputs

Speakers are connected using the high-current five-way binding posts, speakon connectors, or both.

stereo/parallel

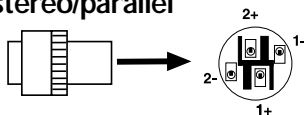

A and B channel
 Speaker + to PIN 1+
 Speaker - to PIN 1-

A channel also has
 B channel + to PIN 2+
 B channel - to PIN 2 -

Note: This is useful in
 bi-amp monitor situations

see—operation modes

bridged mono

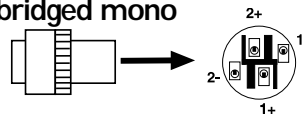

A Channel ONLY
 Speaker + to PIN 1+
 Speaker - to PIN 2+

Very high current is available at the outputs.



Please connect your output cable to the + and - terminals of each section precisely as shown.

stereo mode five-way binding post connectors

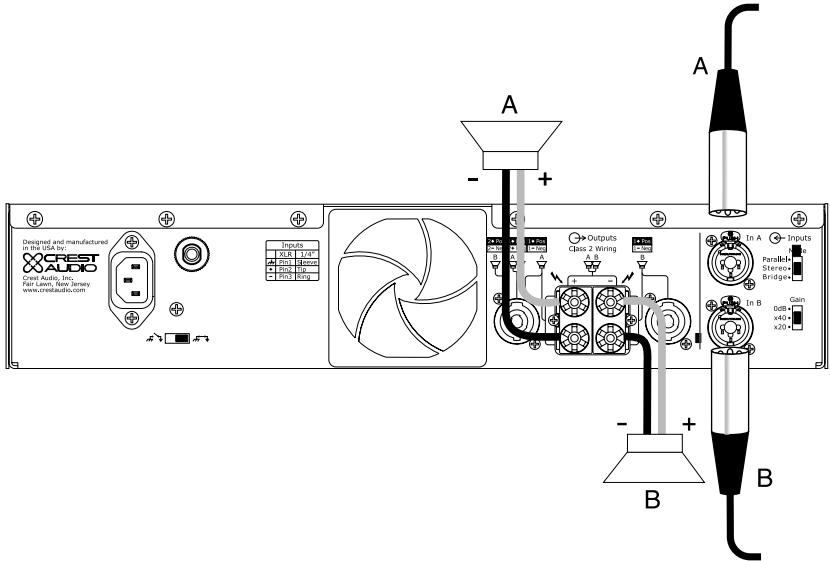

parallel mode five-way binding post connectors

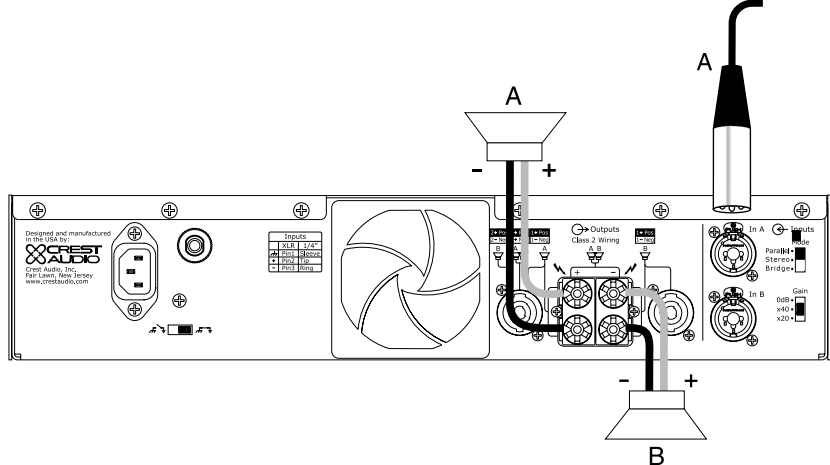

bridged mono mode five-way binding post connectors

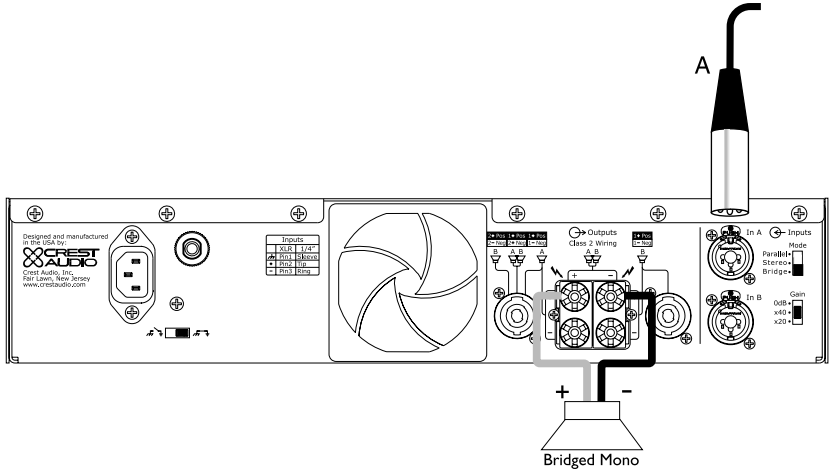

5 connections

stereo mode speakon output connectors

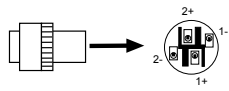

Speaker + to PIN 1 +
Speaker - to PIN 1 -

! The Channel A Speakon has the signal from channel B present on PIN 2- and Pin 2 +.

This is handy in situations where the output is driving bi-amped monitors.

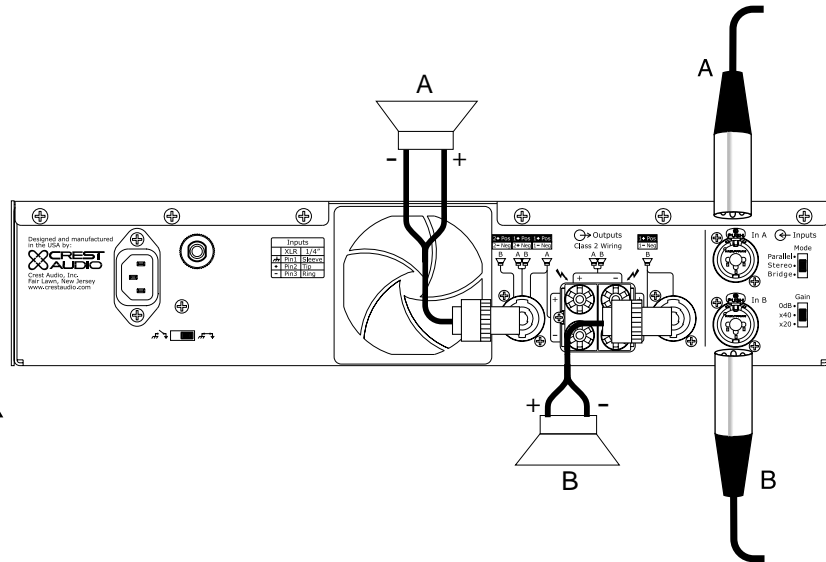

parallel mode speakon output connectors

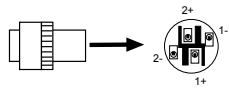

Speaker + to PIN 1 +
Speaker - to PIN 1 -

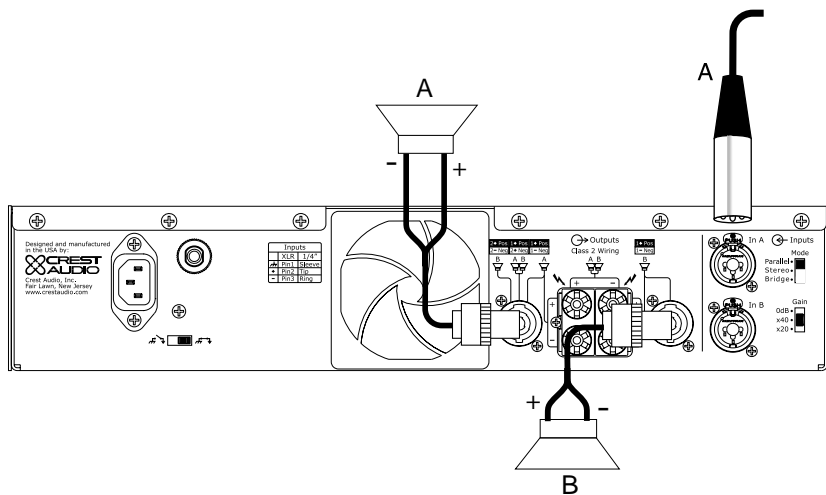

bridged mono mode speakon output connectors

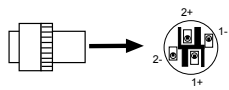

Speaker + to PIN 1 +
Speaker - to PIN 2 +

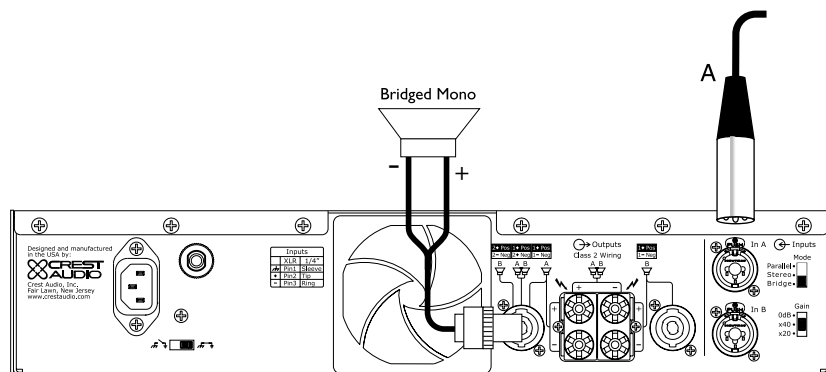

- the owner's role in amplifier safety
- protecting your speakers
- description of TourClass protection features

user
responsibility

speaker
protection

TourClass

user responsibility

Your CD Series amplifier is very powerful and can be potentially dangerous to loudspeakers and operators alike. It is your responsibility to read important precautions (see the inside-front cover) and make sure that the amplifier is installed, wired, and operated properly as instructed in this manual.

Many loudspeakers can be easily damaged or destroyed by overpowering, especially with the high power available from a bridged amplifier. Always be aware of the speaker's continuous and peak power capabilities. Crest Audio is not responsible for damage to loudspeakers for any reason.

see—speaker protection

speaker protection

All loudspeakers have electrical, thermal and physical limits which must be observed to prevent damage or failure. Cone or compression drivers can be damaged (sometimes to the point of failure) from excessive power, low frequencies applied to high frequency drivers, severely clipped wave forms, and DC voltage. All CD Series amplifiers automatically protect speakers from DC voltages and subsonic signals.

see—TourClass protection

Mid- and high-frequency transducers—compression drivers in particular—are highly susceptible to damage from overpowering, clipped wave forms, or frequencies below their rated pass band. When using an electronic crossover, make absolutely certain that the low and mid bands are connected to the correct amplifiers and drivers—and not accidentally connected to those for a higher or lower frequency band.

The amplifier's clipping point is its maximum peak output power. At maximum peak output power, Crest Audio CD Series amplifiers will deliver more power than many speakers can safely handle. Be sure the peak power capability of the amplifier is not excessive for your speaker system. To ensure that the speakers never receive excessive power, and to prevent amplifier clipping, use a properly adjusted external limiter (or a compressor with a ratio of 10:1 or higher) to control power output. Use one compressor/limiter for each frequency band in systems with active electronic crossovers.

The ACL clip limiting circuit will automatically limit the duration of squared-off, continuous wave forms applied to the speakers. The amplifier will, however, allow normal musical transient bursts to pass. Of course, when the amplifier does clip, it is operating at its maximum output power. Note that some speaker systems are packaged with proprietary "processors" that have power limiting circuits and therefore should not require additional limiting. Do not drive any low-frequency speaker enclosure with frequencies lower than its own tuned frequency; the reduced acoustical damping could cause a ported speaker to bottom out even at moderate power. Consult the speaker system specifications to determine its frequency limits, and employ a roll-off filter if necessary.

recommended speaker cabling

The wire gauge charts will assist you in determining the optimum copper wire gauge for your speaker cables. Remember that the speaker cable resistance robs amplifier power in two ways: through power lost directly to resistance (often referred to as I^2R loss), and through increased total load resistance, which decreases the amount of power available from the amplifier. Appendix C gives cable length figures in feet/AWG wire gauges and in metric values.

see—wire gauge

TourClass® protection

Just like Crest Audio's highly acclaimed Pro series amps, CD series amps incorporate TourClass protection features. Derived from Crest Audio's extensive experience with the world's largest sound rental companies, the TourClass group of circuits sets the industry standard for assured protection of internal amplifier circuits and all connected loads.

ACL ACTIVE CLIP LIMITING

At the amplifier's full power limit, or clipping point, ACL will be activated. This is indicated by illumination of the ACL / IGM LED. The channel gain is automatically reduced, protecting the loudspeakers from potential damage from the high power, continuous square waves that would otherwise be produced. ACL may be activated by uncontrolled feedback, oscillations, improper equipment gain settings, or an equipment malfunction upstream from the amplifier. Only steady or excessive clipping (not normal program transients) will trigger ACL. The circuit is virtually transparent in operation and full signal bandwidth is maintained.

IGM INSTANTANEOUS GAIN MODULATION

IGM is an innovative circuit that allows the amplifier to operate safely into loads as low as 4 ohms. When the amplifier sees a load that overstresses the output stage, the IGM circuit adjusts the channel gain to a safe level. This gain control circuit is inaudible in normal use. In addition, if extreme and sustained low impedance is encountered, the amplifier's output relay will open.

AutoRamp

Auto Ramp operates every time the amplifier is turned on or is reactivated after a protect condition is corrected. This exclusive Crest Audio feature gradually increases gain to the attenuator setting avoiding unnecessary stress on the loudspeakers.

Thermal Protect

Abnormally high heat sink temperatures will engage the Protect circuit and disconnects the output relays. During this time the Prot LEDs will light red. The cooling fan will continue running at high speed. Normal operation resumes once the amplifier cools to a safe level.

Short Circuit

If an output is shorted (*i.e.* defective speakers or crossed speaker wires) the output relays will open and the channel will shutdown. After approximately 2 seconds the channel will attempt an AutoRamp re-start. If the short is still present the cycle will repeat. If the short is removed the channel will complete a re-start and operate correctly.

DC Voltage

If an amplifier channel detects DC voltage at its output terminals, the output relay will immediately open to prevent loudspeaker damage. The protect LEDs illuminate.

Subsonic Frequencies

Built-in high pass filtering provides subsonic frequency protection for each channel. In addition, a relay will open if excessive subsonic energy appears at the output.

service and support 7

- when to get support
- ways to contact Crest Audio

support

contact us

support

In the unlikely event that your amplifier develops a problem, it must be returned to an authorized distributor, service center, or shipped directly to our factory.

To obtain service, contact your nearest Crest Audio Service Center, Distributor, Dealer, or any of the worldwide Crest Audio offices. For those with Internet access, please visit the Crest Audio web site.

contact us

customer service

phone 201.909.8700 USA
fax 201.909.8744 USA
email customerserve@crestaudio.com

technical support

phone 201.909.8700 USA
fax 201.587.0550 USA
email techserve@crestaudio.com

web site

www.crestaudio.com

mail

Crest Audio Inc.
16-00 Pollitt Drive
Fair Lawn, NJ 07410 USA

For replacement
packaging, call Crest
Audio's Customer Service 

CD Series

	1kHz, 0.2%THD+N	1000	1500	2000	3000
Stereo power	8Ω	280W	400W	560W	800W
	4Ω	500W	750W	1000W	1500W
	2Ω ¹	500W	750W	1000W	1500W
Bridged mono power	8Ω	1000W	1500W	2000W	3000W
	4Ω ¹	1000W	1500W	2000W	3000W
Maximum output voltage	rms each channel ¹ 1kHz, 0.4%THD+N	53 Vrms	64 Vrms	72 Vrms	85 Vrms
Frequency response	1W @ 8Ω	20Hz-20kHz, +1/-1dB	20Hz-20kHz, +1/-1dB	20Hz-20kHz, +1/-1dB	20Hz-20kHz, +1/-1dB
Power bandwidth @ rated power		20Hz-20kHz, +1/-1dB	20Hz-20kHz, +1/-1dB	20Hz-20kHz, +1/-1dB	20Hz-20kHz, +1/-1dB
Damping Factor		400:1 @ 8Ω	400:1 @ 8Ω,	400:1 @ 8Ω,	400:1 @ 8Ω,
Input sensitivity for full rated output power	Input cmrr	60dB @ 1 kHz	60dB @ 1 kHz	60dB @ 1 kHz	60dB @ 1 kHz
		0.775V / X20 / X40	0.775V / X20 / X40	0.775V / X20 / X40	0.775V / X20 / X40
Input impedance		20K balanced /	20K balanced /	20K balanced /	20K balanced /
		10K unbalanced	10K unbalanced	10K unbalanced	10K unbalanced
Hum and noise (A-weighted below rated power)		>-100dB	>-100dB	>-100dB	>-100dB
Crosstalk		>-60dB @ 1kHz below rated power	>-60dB @ 1kHz below rated power	>-60dB @ 1kHz below rated power	>-60dB @ 1kHz below rated power
Class		D	D	D	D
Circuit breaker rating 120Vac		10A	12A	15A	20A
Circuit breaker rating 230Vac		6A	8A	10A	12A
Current draw 1/8 power, 4Ω 120Vac		2.6A	3.6A	4.5A	7.0A
Current draw 1/3 power, 4Ω 120Vac		5.3A	7.5A	9.6A	14.0A
Current draw idle 120Vac		1.0A	1.1A	1.25A	1.5A
Thermal emissions 1/3 Power, 4Ω, BTU/HR		484	614	781	1024
Cooling		Back to front via variable speed fan (all models)			
Input connectors , per channel		Female XLR pin 2+, 1/4" TRS Combo connectors (all models)			
Output connectors		Speakon connectors and 5 way binding post (all models)			
Controls		Front panel: two attenuators, power switch. Rear panel: signal ground-lift, mode select, circuit breaker (all models)			
LED indicators		ACL, IGM, protection, 5 segment bargraph VU meter, Active (all models)			
TourClass protection		ACL, IGM, AUTORAMP, short circuit, DC Voltage Turn ON/OFF transient, current in-rush, sub/ultrasonic input (all models)			
Construction		16 guage steel chassis			
Dimensions		Inches: 3.5 height x 19 width x 15.3 depth / MM: 89 height x 483 width x 389 depth (all models)			
Weight net		30 lbs / 13.6 kG	35 Lbs / 15.9 kG	38 Lbs / 17.2 kG	41.4 Lbs / 18.8 kG

b block diagram

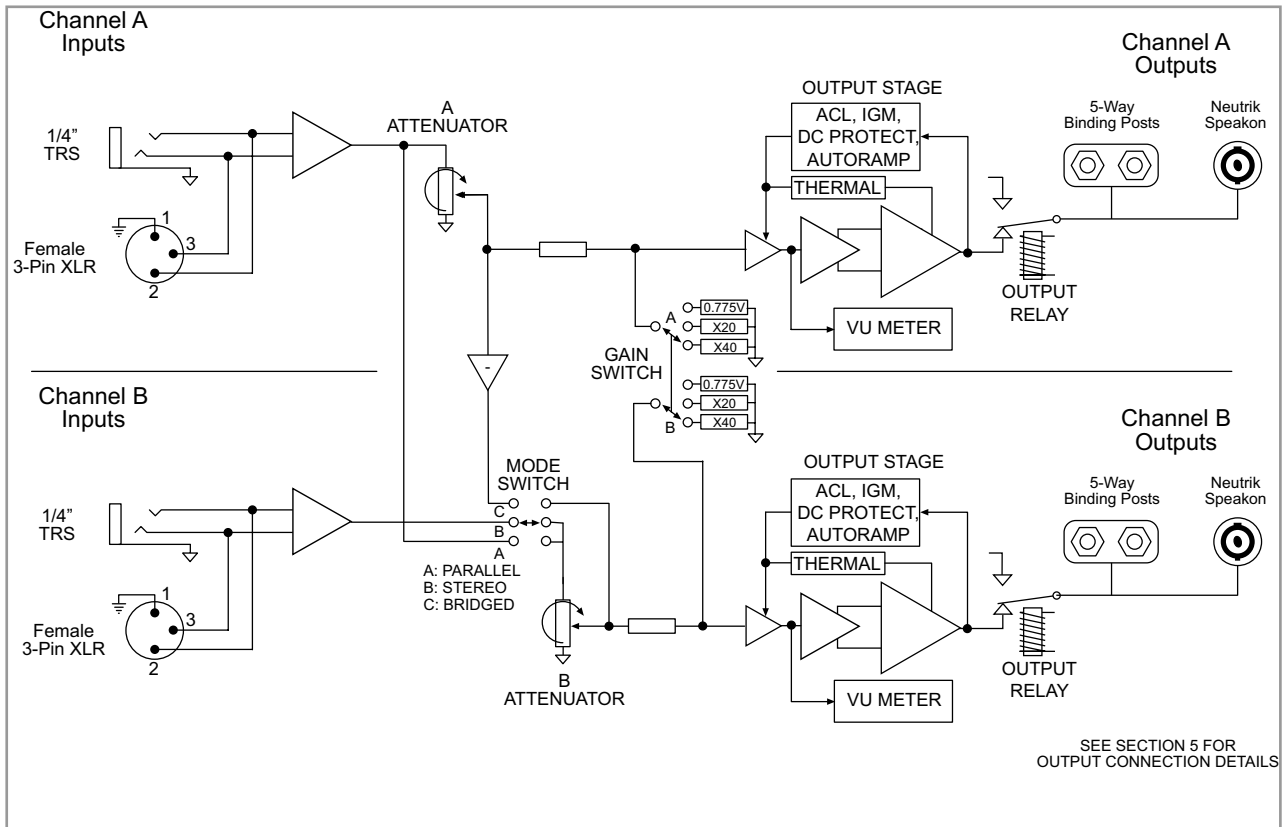

optional handle installation C

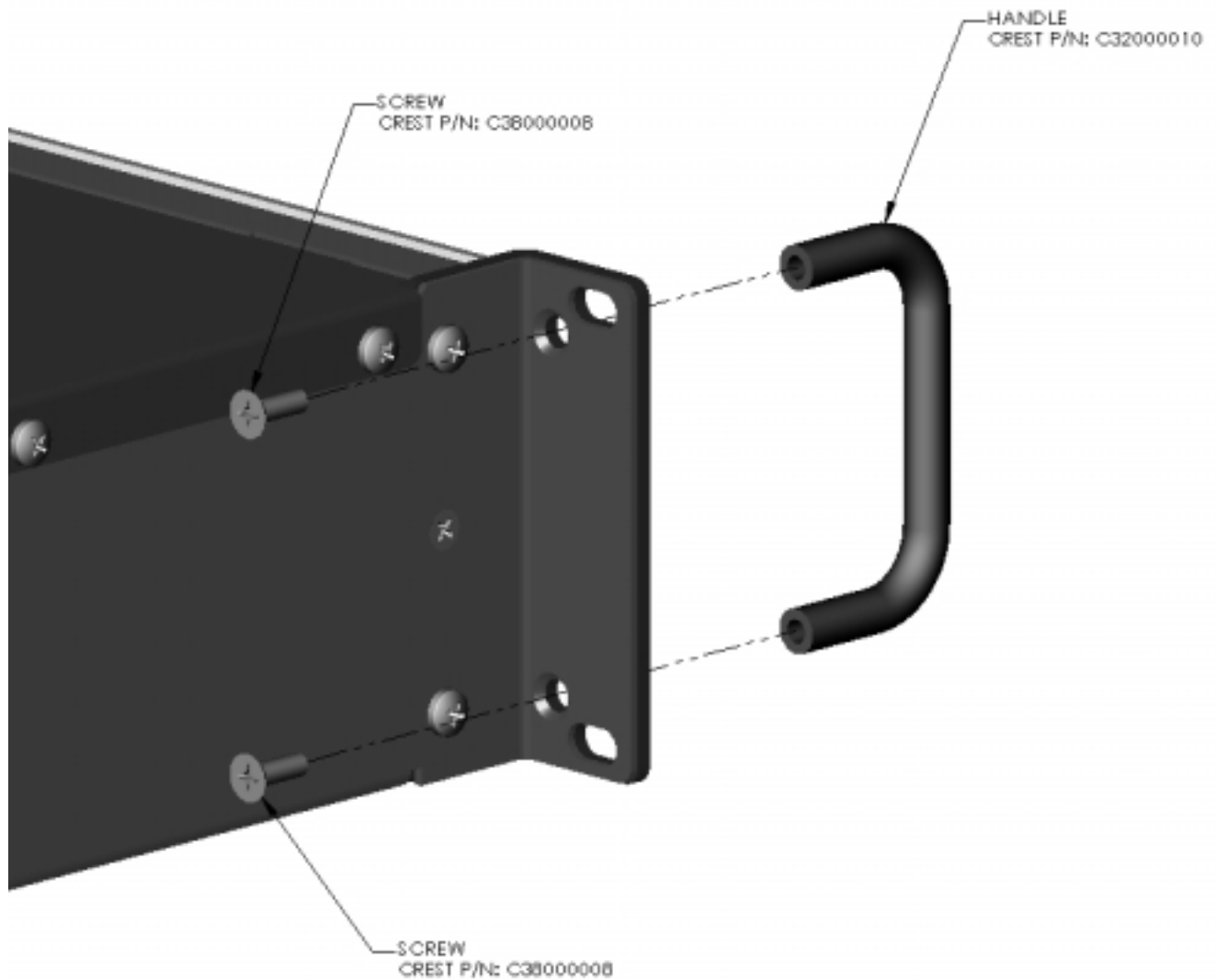

The CD amplifiers can be outfitted with optional handles. This option requires (2) CD series handles (P/N C32000010) and (4) #8-32 1/2" undercut flat head screws (P/N C38000008). You may order these from your dealer or directly from Crest Audio.

stranded cable length	wire gauge	8 Ω load	4 Ω load	power loss 2 Ω load
2 meters	0.3mm ²	2.9%	5.6%	10.8%
	0.5	1.74	3.4	6.7
	0.75	1.16	2.3	4.5
	1.5	0.58	1.16	2.3
	2.5	0.35	0.70	1.39
	4.0	0.22	0.44	0.87
5 meters	0.5mm ²	4.3%	8.2%	15.5%
	0.75	2.9	5.6	10.8
	1.5	1.45	2.9	5.6
	2.5	0.87	1.74	3.4
	4	0.55	1.09	2.2
	6	0.37	0.73	1.45
10 meters	0.5mm ²	8.24%	5.5%	28%
	0.75	5.6	10.8	19.9
	1.5	2.9	5.6	10.8
	2.5	1.74	2.9	6.7
	4	1.09	1.74	4.3
	6	0.73	1.09	2.9
30 meters	0.75mm ²	15.5%	0.73%	45%
	1.5	8.2	15.5	28
	2.5	5.1	9.8	18.2
	4	3.2	6.3	12.0
	6	2.2	4.3	8.2
	10	1.31	2.6	5.1

wire gauge d

stranded cable length	wire gauge	8 Ω load	4 Ω load	power loss 2 Ω load
5 feet	18AWG	0.81%	1.61%	3.2%
	16	0.51	1.02	2.0
	14	0.32	0.64	1.28
	12	0.20	0.40	0.80
	10	0.128	0.25	0.51
10 feet	18AWG	1.61%	3.2%	6.2%
	16	1.02	2.0	4.0
	14	0.64	1.28	2.5
	12	0.40	0.80	1.60
	10	0.25	0.51	1.01
40 feet	18AWG	6.2%	11.9%	22%
	16	4.0	7.7	14.6
	14	2.5	5.0	9.6
	12	1.60	3.2	6.2
	10	1.01	2.0	4.0
	8	0.60	1.20	2.4
80 feet	18AWG	11.9%	22%	37%
	16	7.7	14.6	26
	14	5.0	9.6	17.8
	12	3.2	6.2	11.8
	10	2.0	4.0	7.7
	8	1.20	2.4	4.7



<http://www.crestaudio.com>

CD Owner's Manual Version 1.1 10/14/04
P/N 80305114